

70x70x15mm

Model C

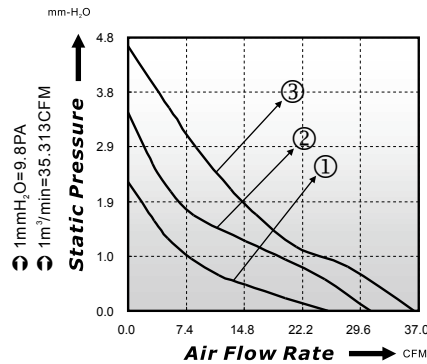

P-Q Curve (At Rated Voltage)



Dimensions Drawing

Unit: (mm)

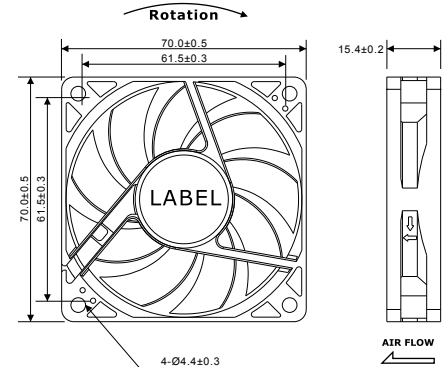

Model No	Bearing (*)	Rated Voltage (VDC)	Rated Current (A)	Power Consumption (Watts)	Speed (rpm)	Air Flow (CFM)	Static Pressure (mmH ₂ O)	Noise (dBA)	Curve
ED07015-12M*	○ ● ⊖	12	0.10	1.20	3000	25.42	2.26	26.5	1
ED07015-12H*	○ ● ⊖	12	0.16	1.92	3600	30.82	3.48	30.4	2
ED07015-12HH*	○ ● ⊖	12	0.30	3.60	4200	36.35	4.65	35.8	3

* Bearing Type: ○ Sleeve ● Two Ball ⊖ Hydro-Dynamic